

Case Minibagger CX 12D

Technische Daten Case Minibagger CX 12D

Max. Grabtiefe	1,86 m	Transport / Höhe	2,30m(1,37m)
Max. Reichweite	3,40 m	Transport / Länge	2,45m
Max. Schütthöhe	2,13 m	Transport / Breite	0,79 m / 1,05 m
Schaufelaufnahme	MS 01	Eigengewicht	1.305 kg

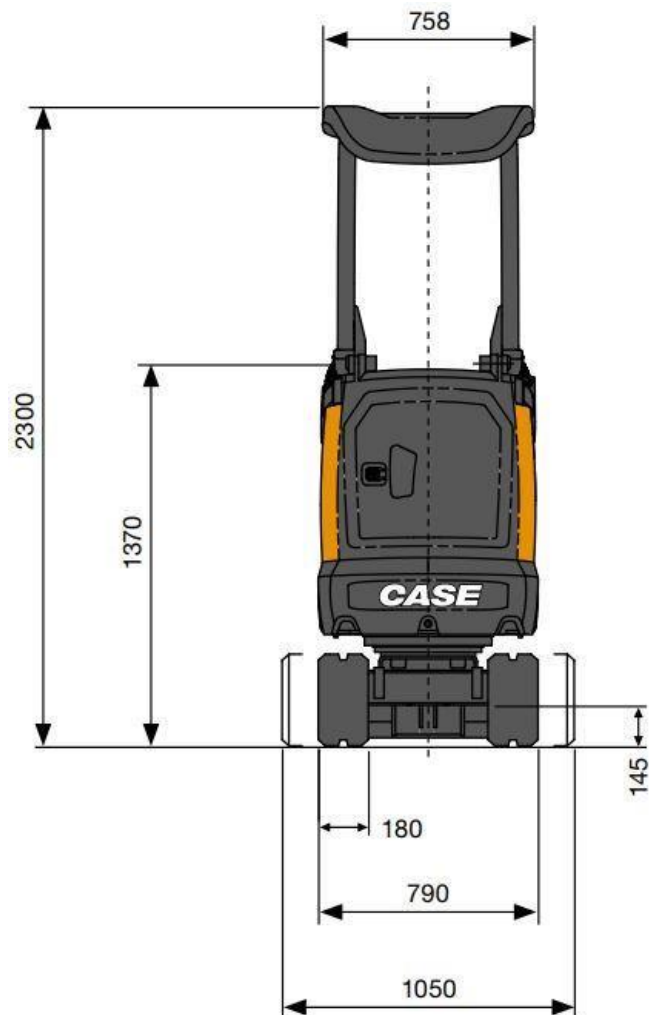

-BLESER G
MIETSTATION H

Arbeitsbühnen · Baumaschinen

Danziger Straße 5 · 56564 Neuwied
Tel. 0 26 31 / 35 61 10 · Fax 0 26 31 / 35 61 12
blesermietstation.de · info@blesermietstation.de

